

Process Modelling

Strategisches Prozessmanagement

Agenda

Business process modelling

Business process maps and characteristics

Business Process Model and Notation

Modelling conventions

Outlook

Is this a contradiction?

Model vs. Real World



A model is an abstraction of a business process (i.e. an image).

The correctness of a business process model can only be confirmed by the owner.

Image taken from a University of Alabama site, "Approaches to Modernism": [1], Fair use, <https://en.wikipedia.org/w/index.php?curid=555365>

Business Process Model and Modeling Language

A **business process model** is an abstraction on a business process as it is executed today or as it is intended to be (e.g. in the future). The model focusses on visualising relevant information and omits unnecessary aspects.

A **business process modeling language** defines concepts for modelling business processes. It consists of rules for constructing valid models (syntax) and an interpretation (semantics).

Is this a business process model?

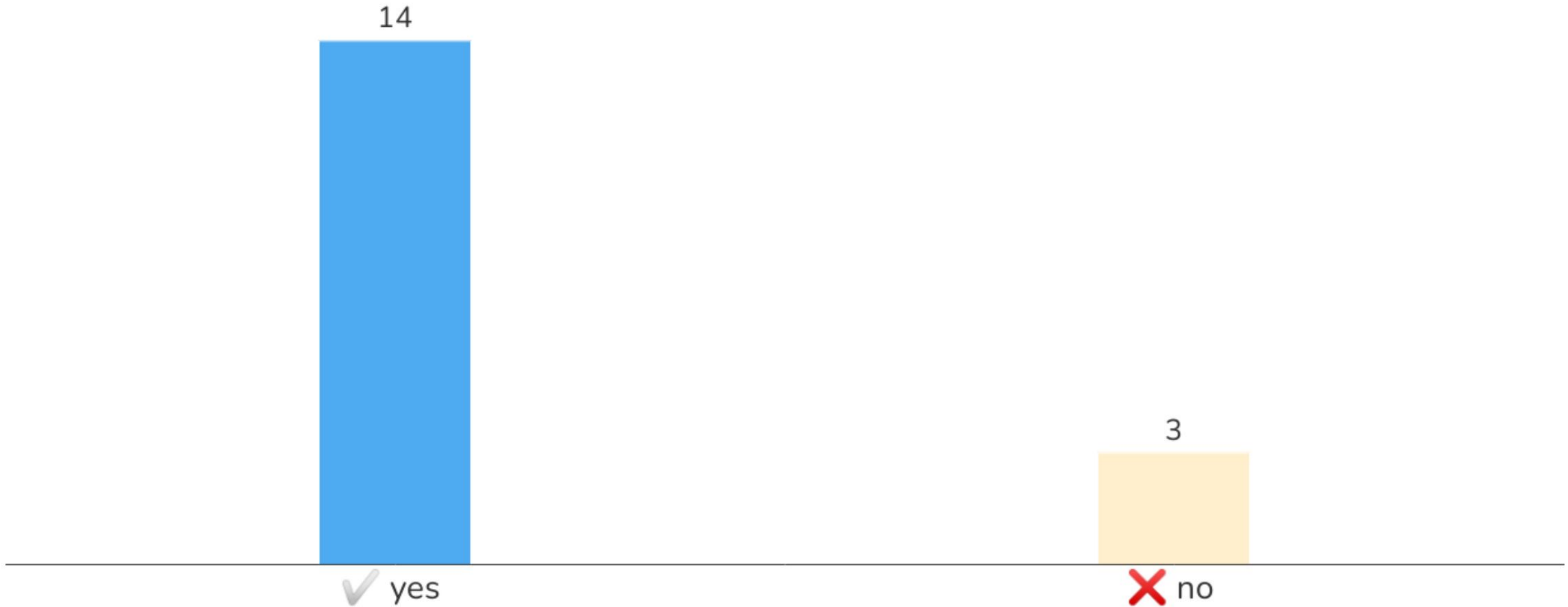

Leaderboard

17 players

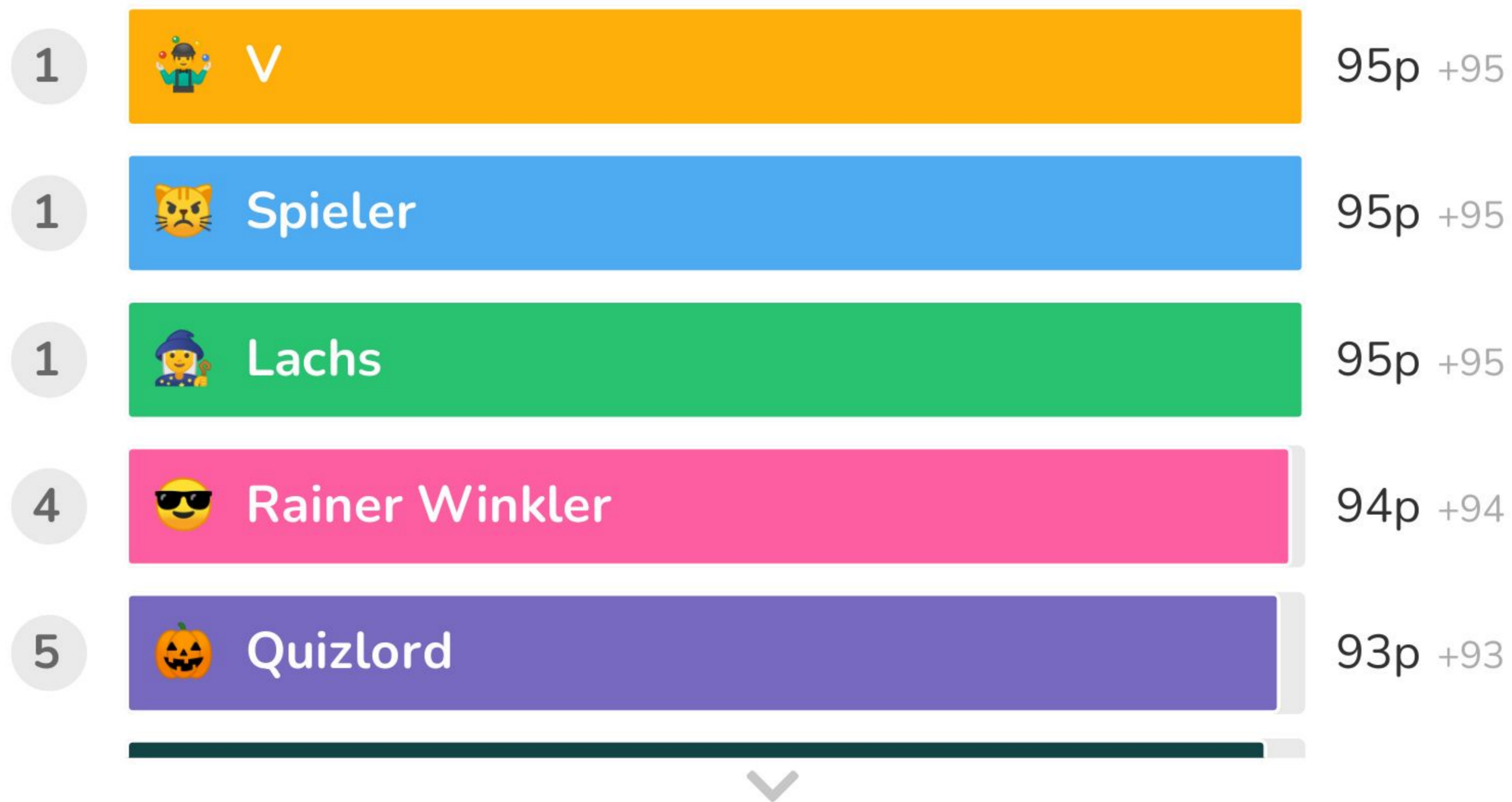

Is this a business process model?

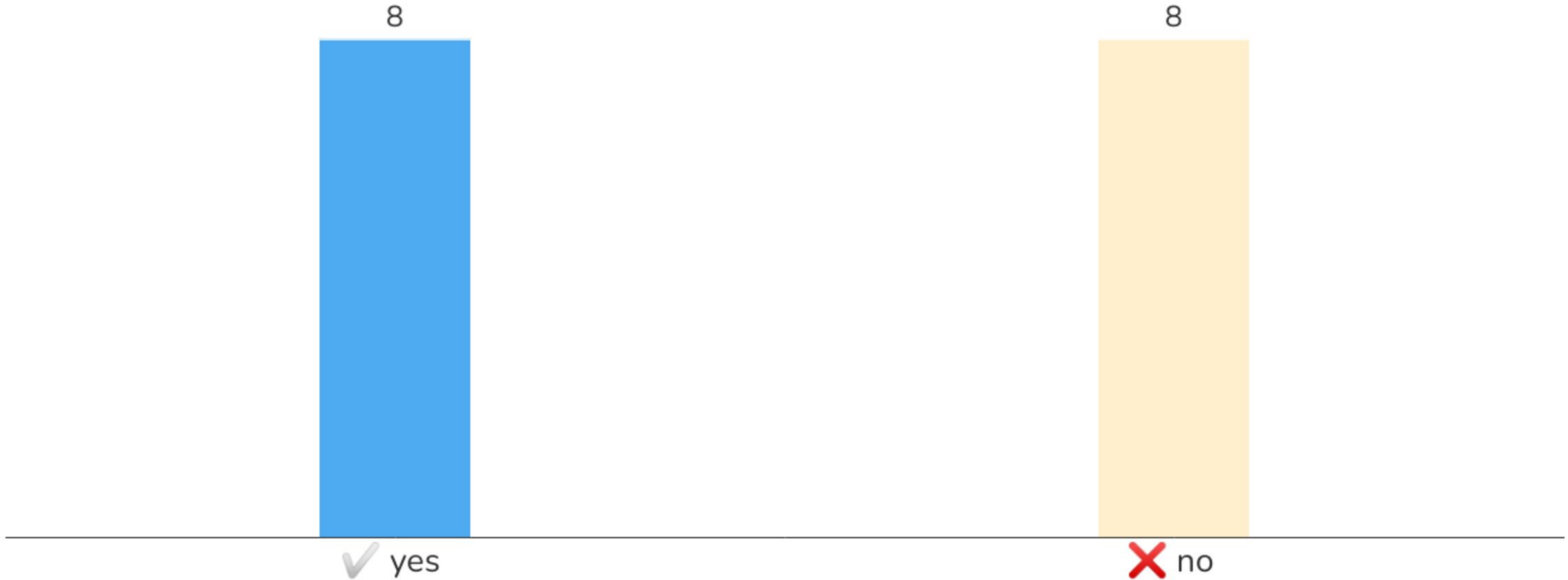

Leaderboard

17 players





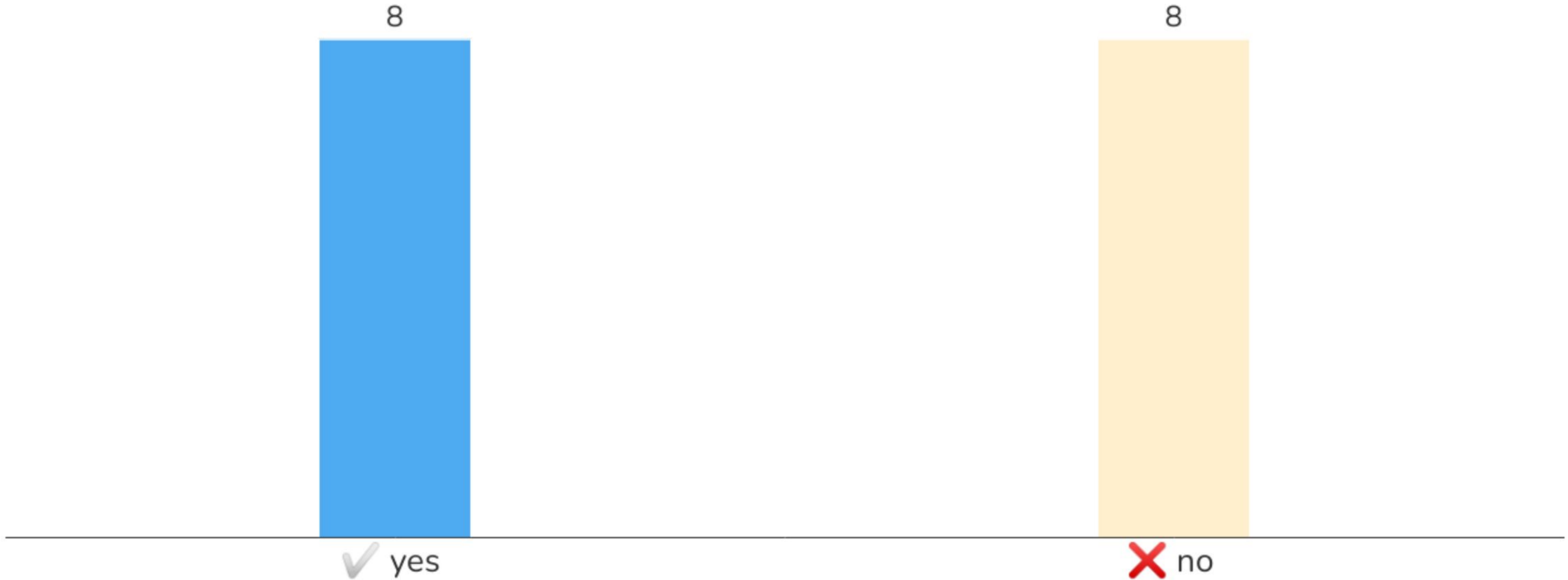



Is this a business process model?



Leaderboard

17 players

x 3

 Lachs is rocking the longest streak!

1	 Lachs	285p +94
2	 Spieler	283p +92
3	 Mäh	279p +92
4	 Rainer Winkler	276p +85
5	 V	100p +0

Challenge with Models

Essentially, all models are wrong, but some are useful.

George Box (1919--2013)

Levels of Abstraction

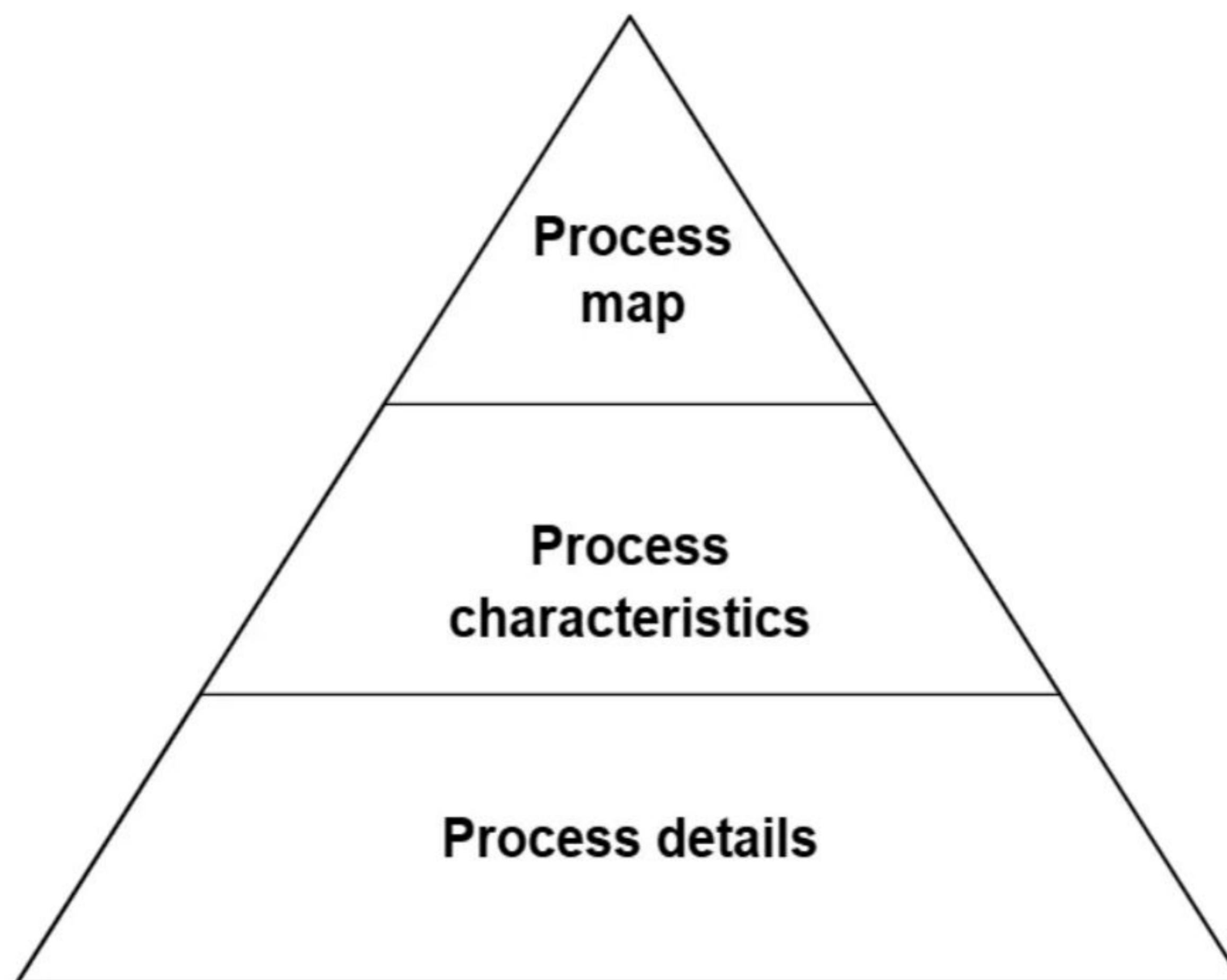

Overview on all relevant processes of a company or an organisational unit

High-level information about business processes and their dependencies

Model with specific information about a process and its execution

Process Maps

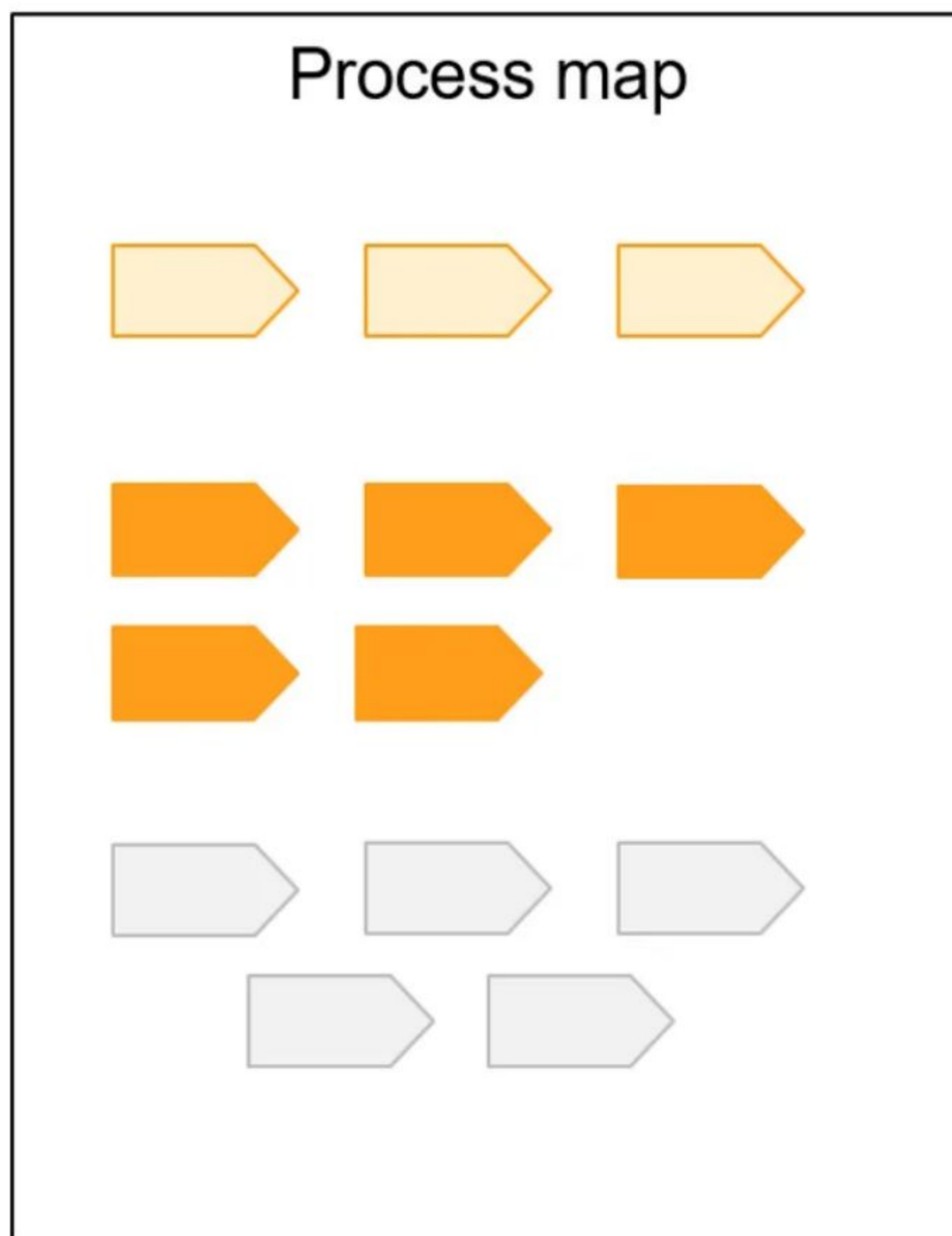

Guiding processes

- Govern the business (long term)
- Plan and control (short term)

Core processes

- Develop products and services
- Satisfy customers and consumers

Enabling processes

- Provide primary resources
- Support with conventional resources

Example Map (logistics)



Example Map (generic)

Guiding Processes

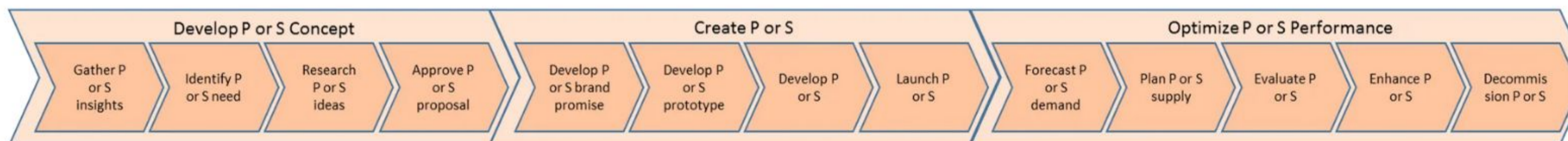

Core Processes

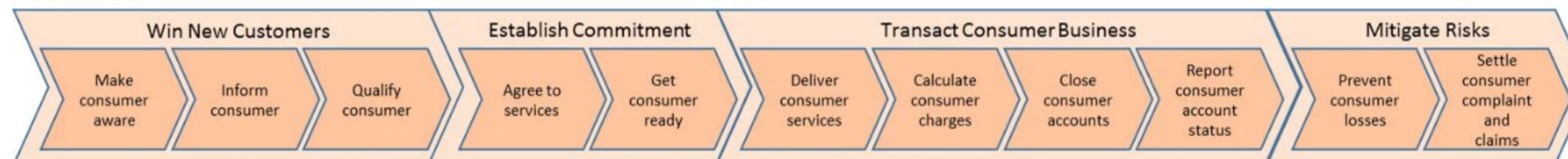

Enabling Processes

<https://bpmtips.com/process-architecture-real-life-examples/>

Process Map (Lego)



©2012 The LEGO Group

<https://bpmtips.com/process-architecture-real-life-examples/>

Levels of Abstraction

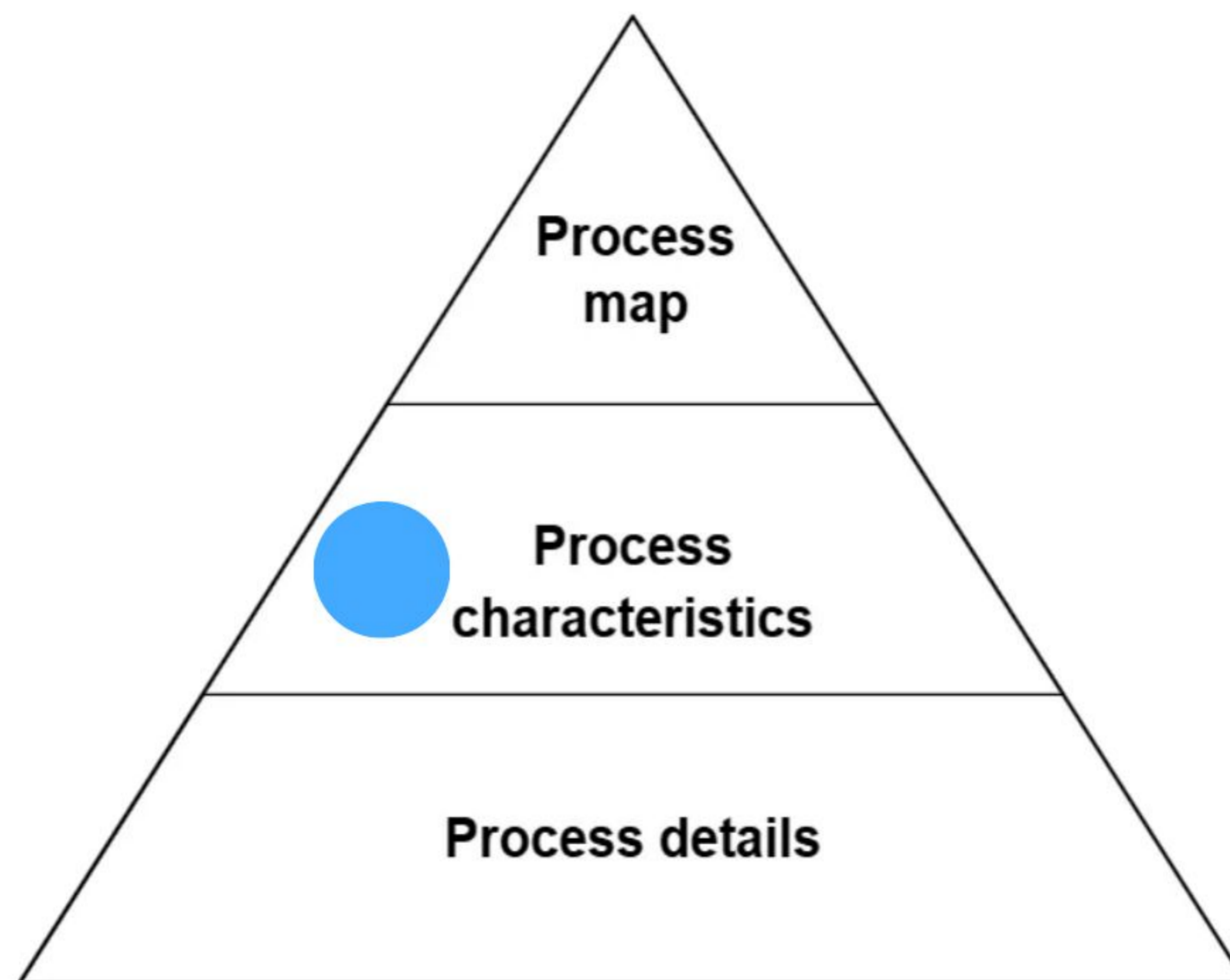

Overview on all relevant processes of a company or an organisational unit

High-level information about business processes and their dependencies

Model with specific information about a process and its execution

Which kind of information is relevant when describing a business process?

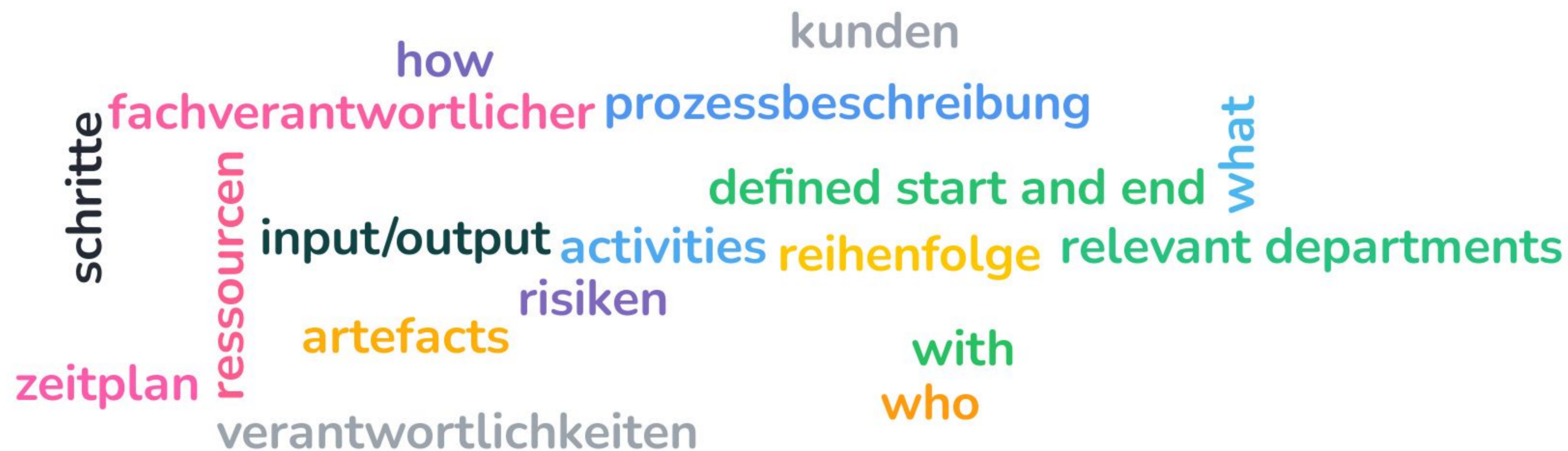

Context of a Business Process

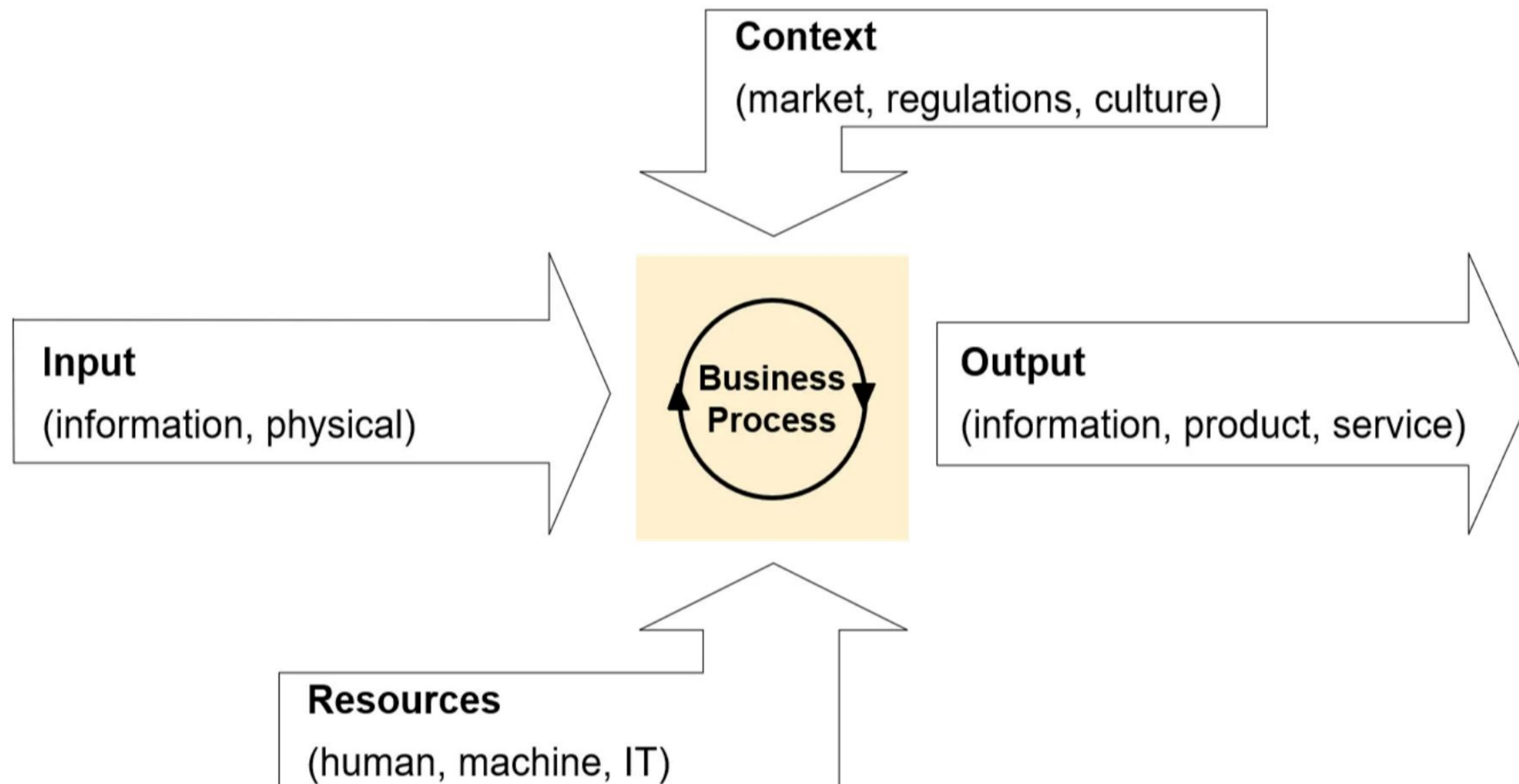

Example Characteristic (1/3)

Process Characteristics			
Process name: Order fulfilment	Date: 2021-12-22		
Purpose: Delivering orders from warehouse to consumers on time	Editor: J. Jung		
Process owner: Order Fulfilment and Warehouse Operations	Interviewee: S. Go		
Input: Consumer order from web shop; inventory; delivery schedule			
Main activities	Participants	IT-Systems	Ressources

Basic information

Process Characteristic (2/3)

Input: Consumer order from web shop; inventory; delivery schedule			
Main activities	Participants	IT-Systems	Ressources
Accept and verify order from webshop		OMS	
Determine fulfilment center, service level and routing		OMS	
Pick goods and create documents	Picker	WMS	Mobile device
Inspect goods/documents and pack them into parcels	Packer	Shipping	Scanner
Sort outbound deliveries and hand over to DSP	Dispatcher	OMS	Scanner

Main activities

Process Characteristic (3/3)

Result: Parcels out for delivery towards consumers

Sub-process of: Order-to-Delivery

Preceding processes: ./.

Following processes: Shipment tracking

Critical success factors: IT integration of order management system (OMS) with webshop and delivery service provider (DSP)

Process context

Anything still missing?

Process Decomposition



Process steps can be decomposed into activities

Example Decomposition

Order fulfillment



Executing a customer order from web shop to door step

Levels of Abstraction

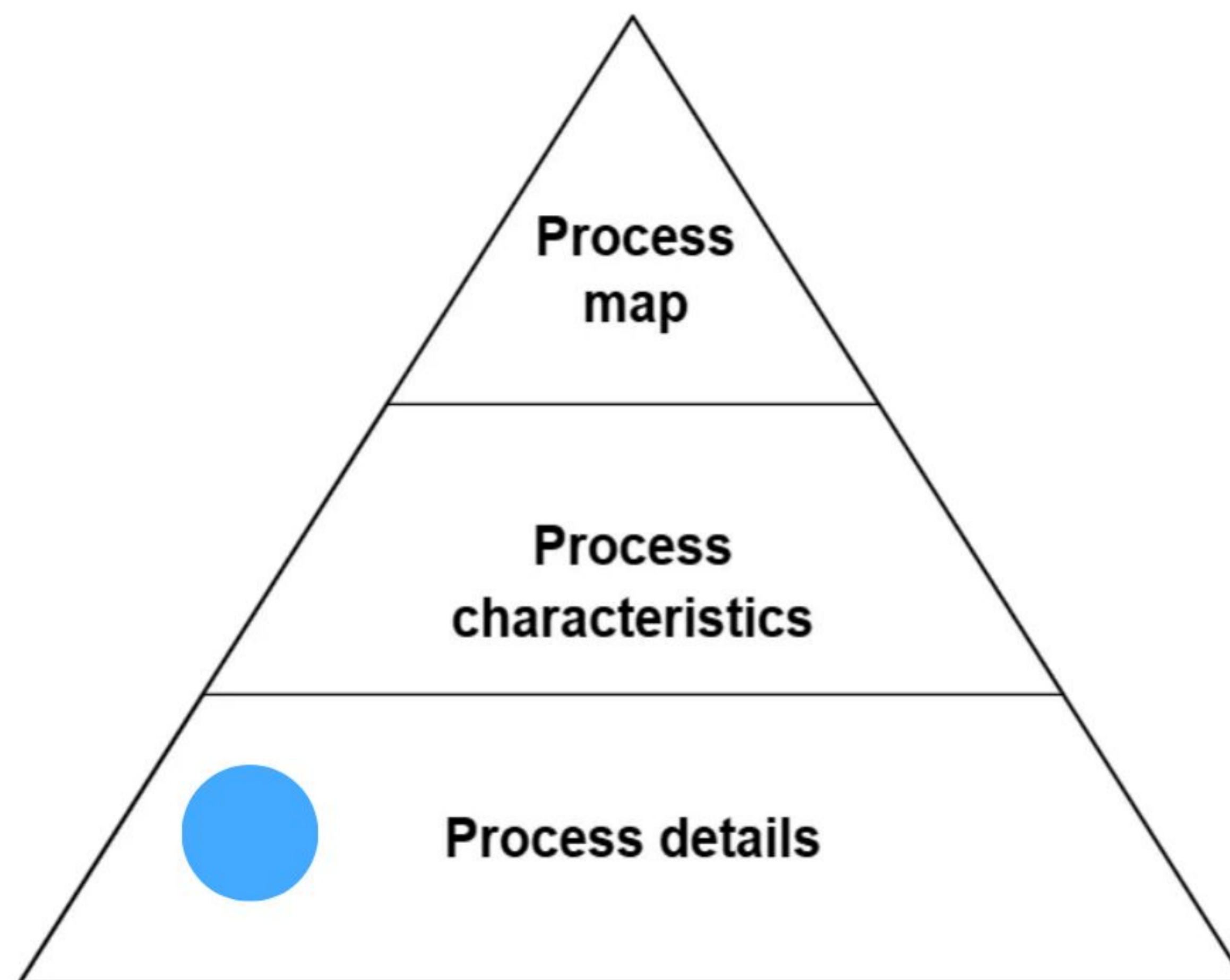

Overview on all relevant processes of a company or an organisational unit

High-level information about business processes and their dependencies

Model with specific information about a process and its execution

Business Process Model Example

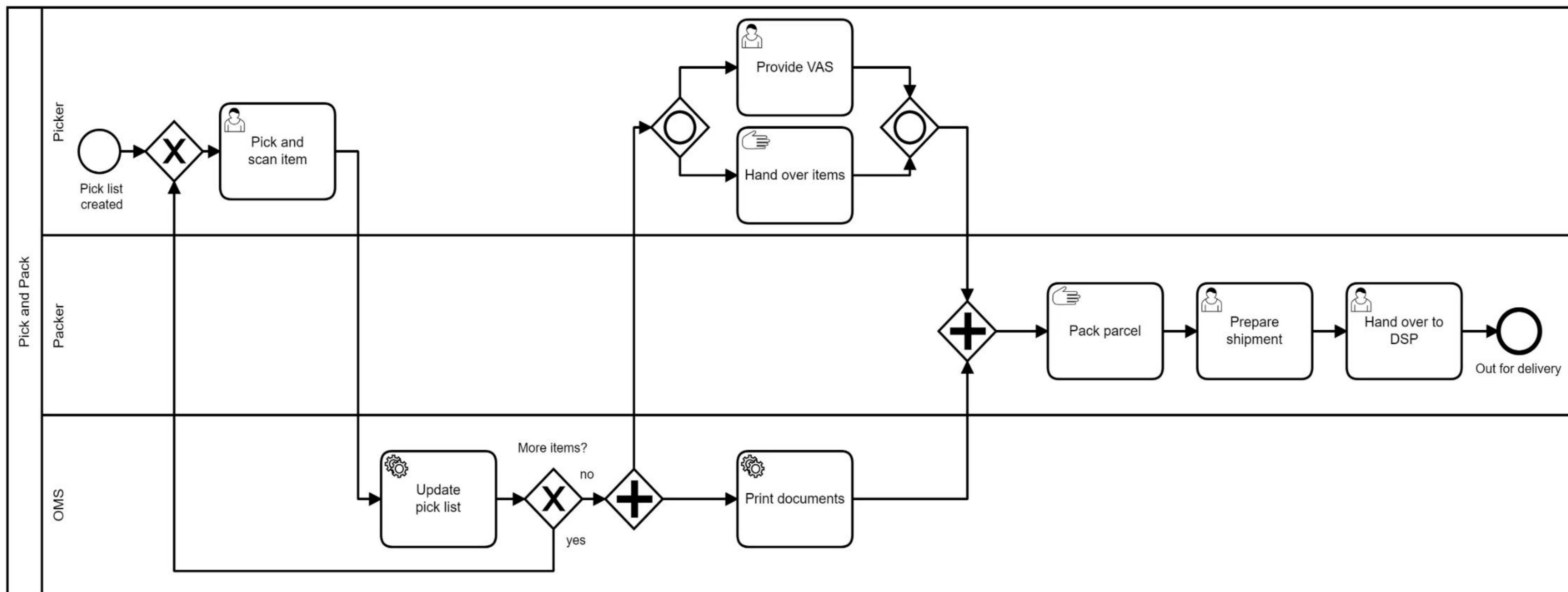



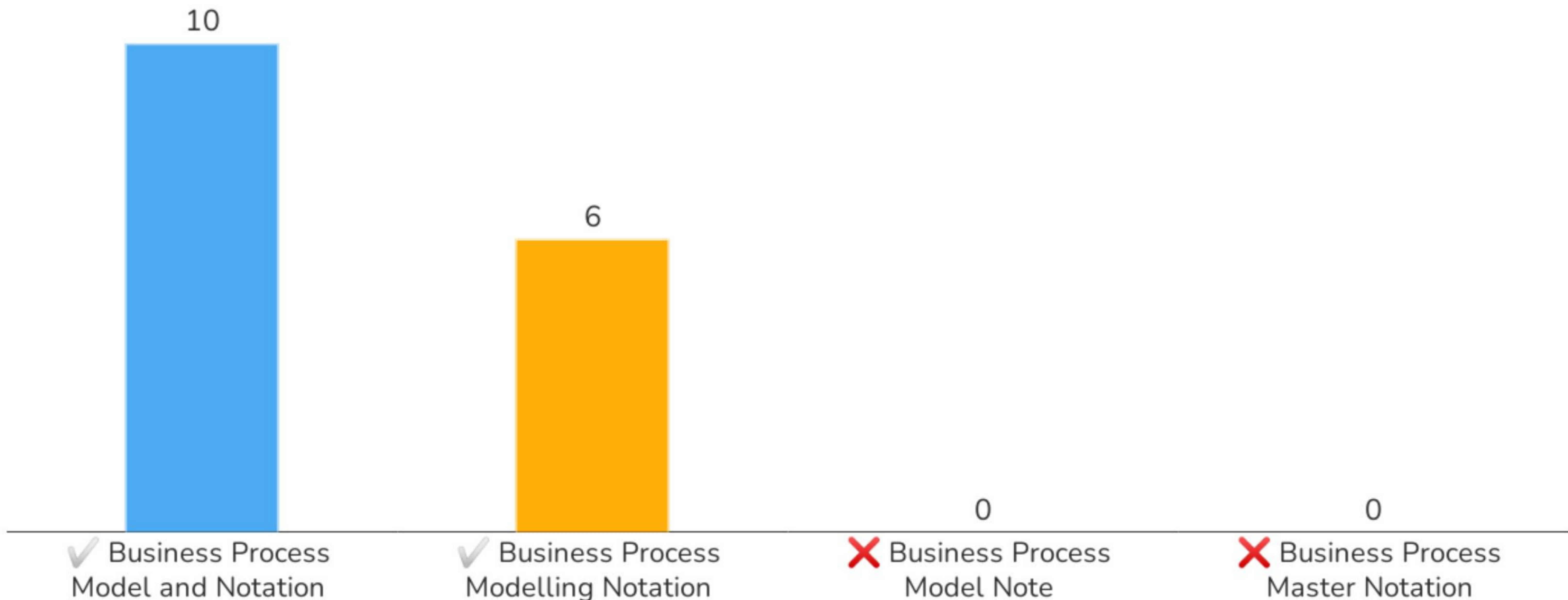



What does BPMN stand for?



Leaderboard

18 players



x 4

 Mäh is rocking the longest streak!

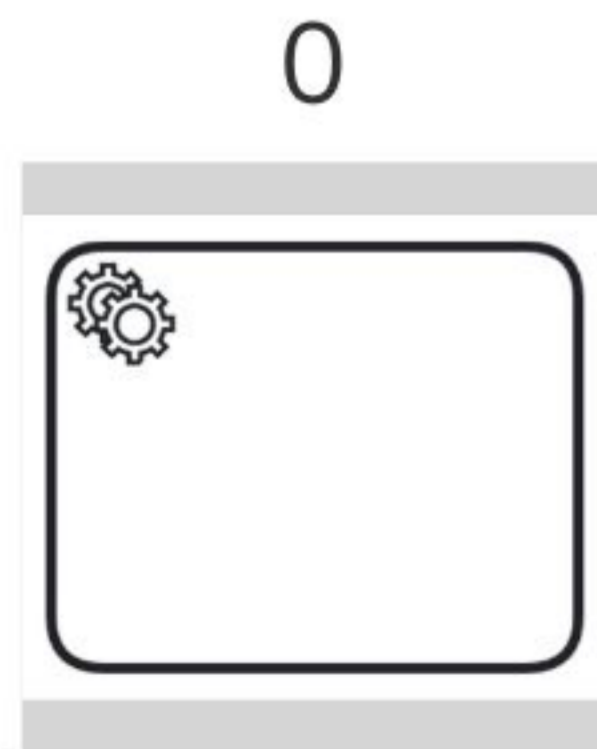
1	 Mäh	358p +79
2	 Spieler	327p +44
3	 Lachs	317p +32
4	 Rainer Winkler	313p +37
5	

Which one shows a gateway?

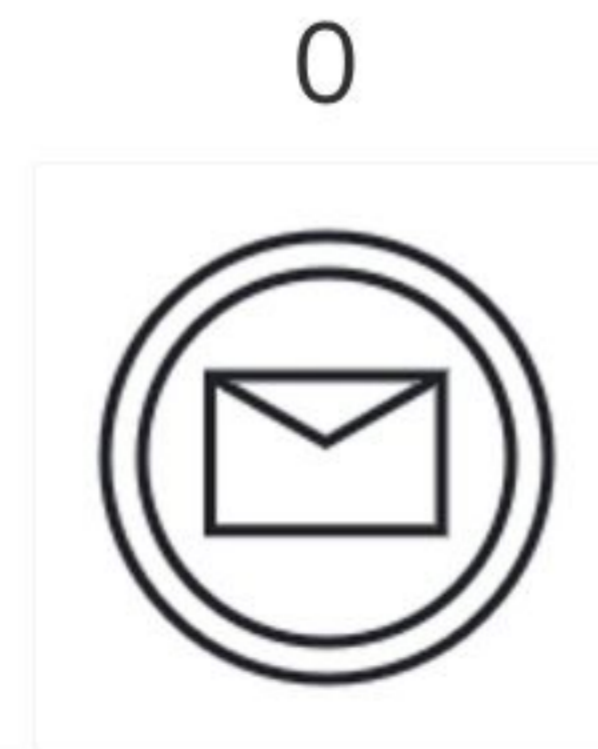

✗



✗

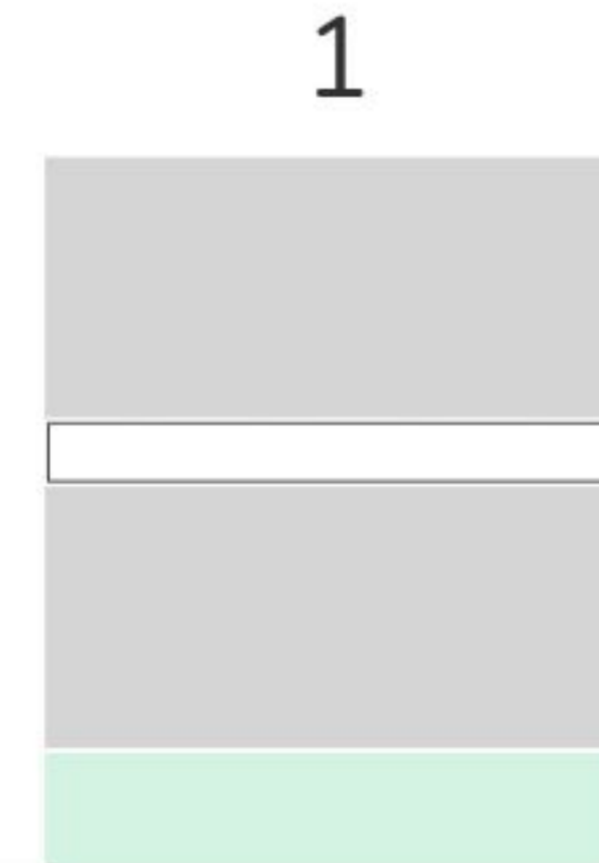

✗



✓

Leaderboard

18 players



x 5



Mäh holds the longest streak record!



Mäh

1	Mäh		446p +88
2	Spieler		421p +94
3	Lachs	446 points	410p +93
4	Rainer Winkler		407p +94
5	...		321p ...

BPMN Elements

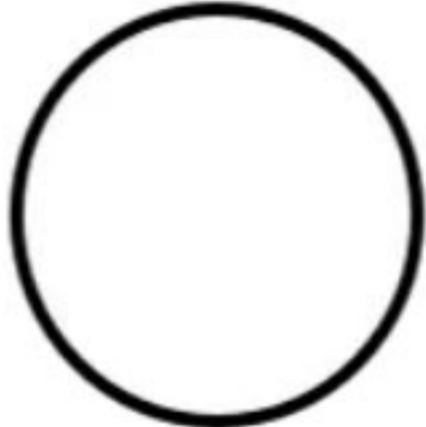
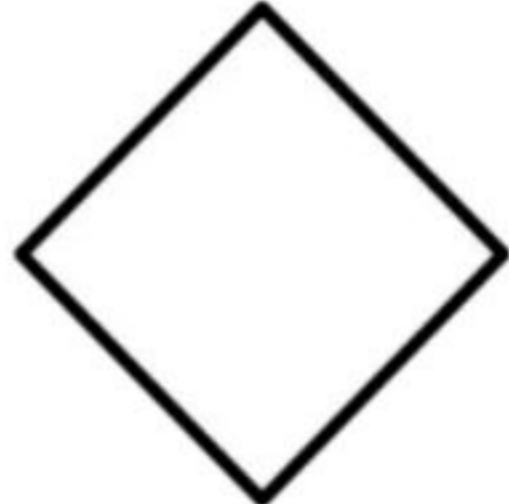
BPMN element	purpose	properties	examples	symbol
Task	<ul style="list-style-type: none"> describing what needs to be done contributes to value chain 	<ul style="list-style-type: none"> activity takes time performed by an actor 	<ul style="list-style-type: none"> provide information approve contract make decision 	
Event	<ul style="list-style-type: none"> describing what happens (or happened) beginning or end of a status 	<ul style="list-style-type: none"> passive doesn't take time result of activity triggers activity 	<ul style="list-style-type: none"> application submitted order approved server crashed 	
Gateway	<ul style="list-style-type: none"> branching synchronisation control flow concurrency 	<ul style="list-style-type: none"> passive timeless condition (boolean expression) 	<ul style="list-style-type: none"> parallel (AND) branch (XOR, OR) 	

Strategic Process Management: Modelling

The *Business Process CoE* is accountable for enabling the modelling of business processes in a corporate environment. This usually requires:

- Provisioning of business process modelling tool
- Definition of modelling standards
- Defining quality criteria for business process models
- Ensuring quality and consistency of process landscape

How would you rate the following as modelling tools?

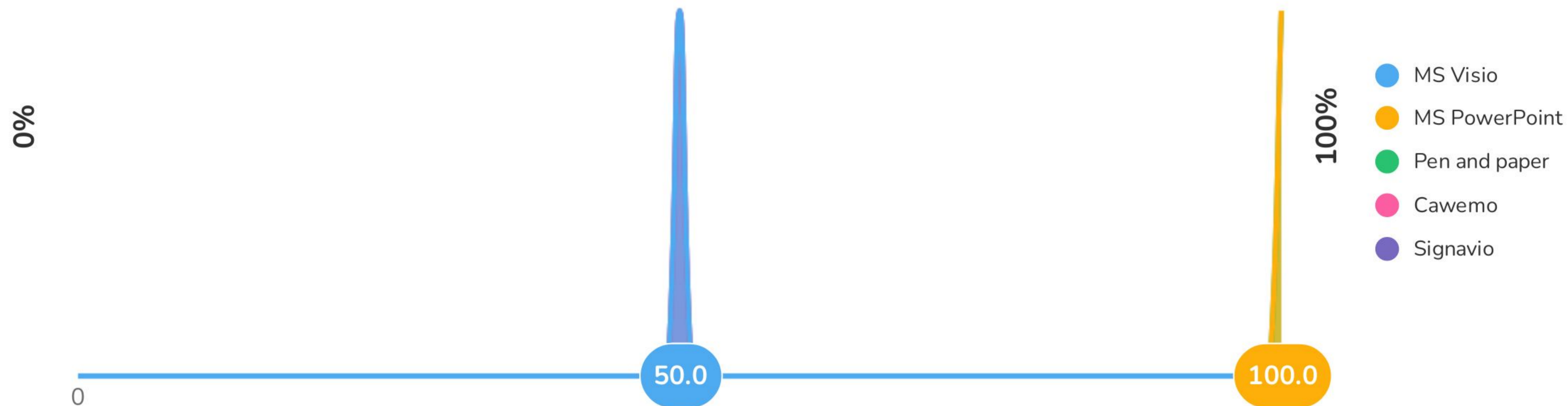

Modelling Conventions (examples)

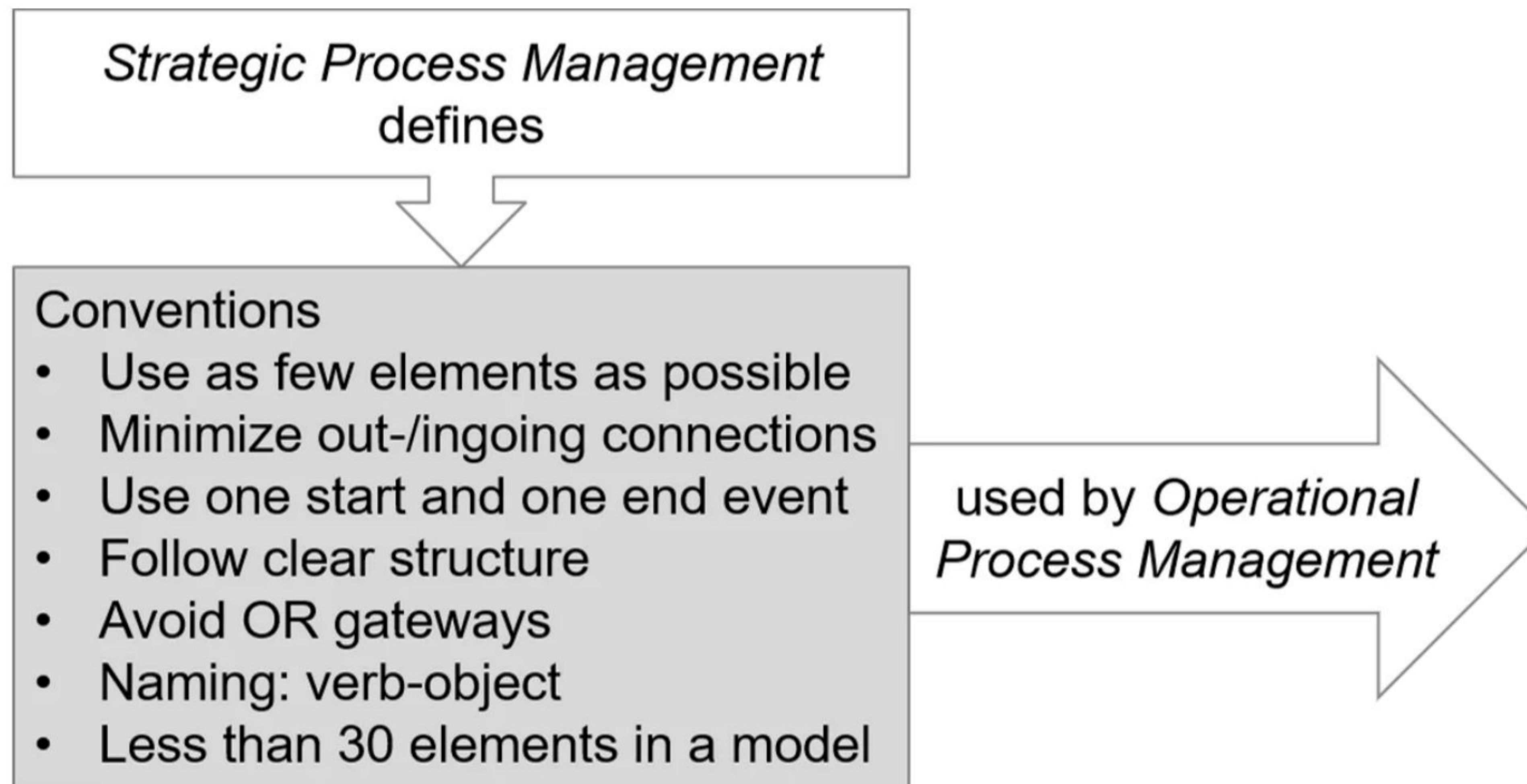

Conventions define process modelling standards

How can we assess the quality of a business process model?

Quality Criteria for Process Models

Some ideas for assessing a model's quality

- Correct: Following modelling standards and conventions
- Comprehensible: Easy to understand by stakeholders
- Adequate: Supporting intended purpose
- Correct: Describing real-wprld process correctly

Ensuring Consistency accross Processes

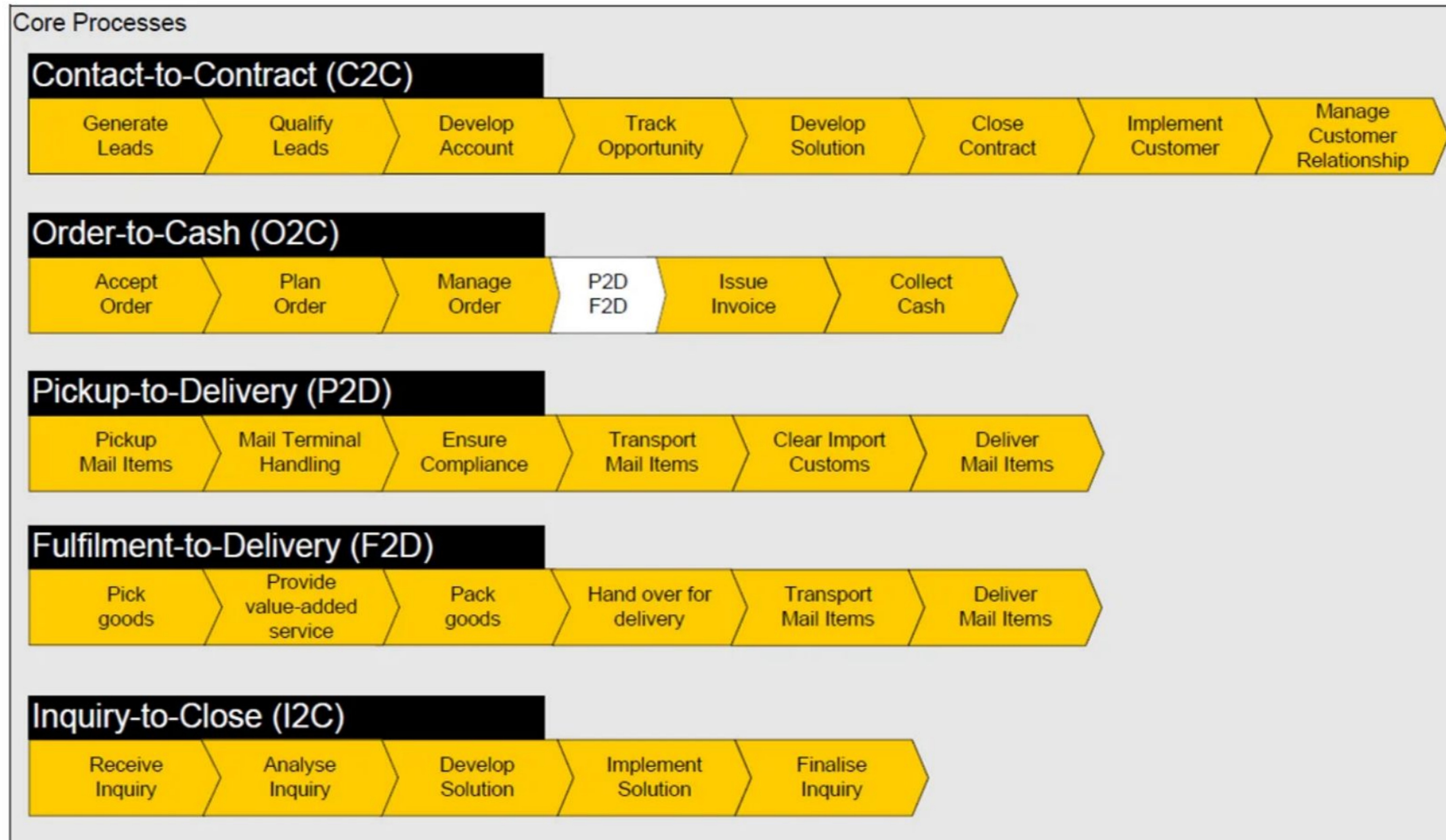

Top questions

There are no unanswered questions.

Pinned

Newest

Oldest

Answered

Exercise 4.1

Which steps do the following Veggie Bowl processes consists of?

1. Order-to-Delivery
2. Order-to-Serve

Find at least 5--7 process steps and explain each of them.

Process steps

Exercise 4.2



Veggie Bowl Restaurant process map

- For each of your core processes
 - How can we measure the success?
 - Which objective is followed by each process?
- Time 45 minutes
- Teams of two

